

# DIAMOND GEAR CO., LTD.

# 942WG1450

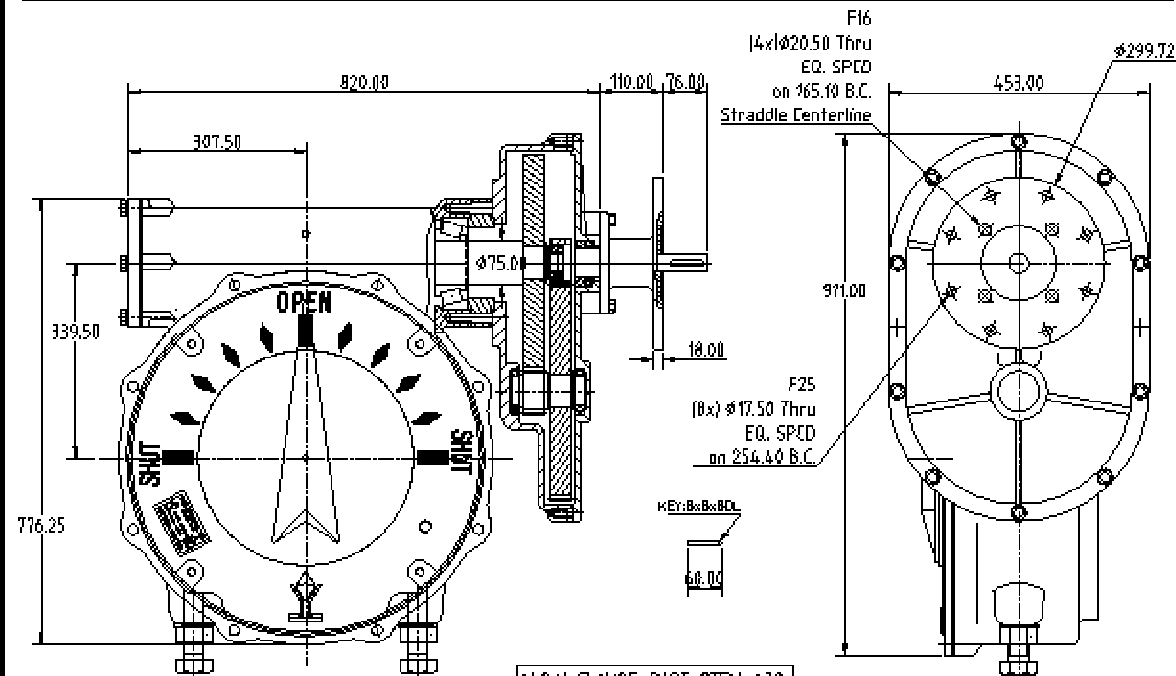

M.O.V FLANGE PART STEM Ø30  
M.O.V FLANGE: ISO F16/F25

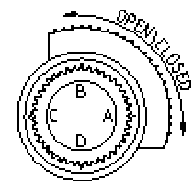
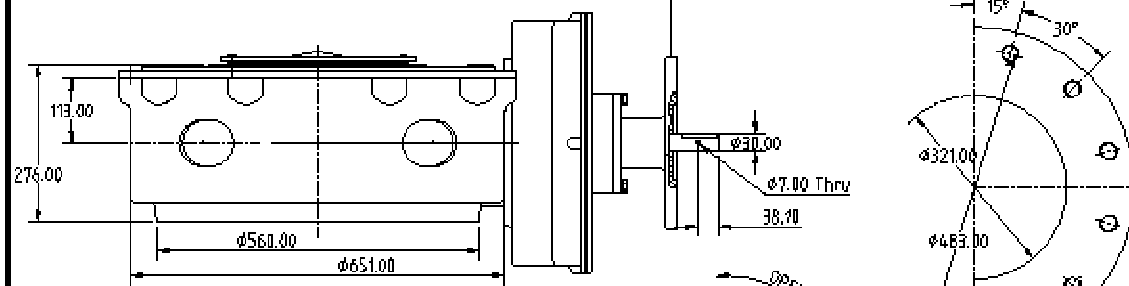

| DI.A. | RIM PULL AT MAX. O/P TORQUE (LBS.) | WEIGHT |
|-------|------------------------------------|--------|
| 24"   | 216                                | 1496   |
| 30"   | 173                                |        |
| 36"   | 144                                |        |

| MAX. OUTPUT TORQUE (IN.LB) | MAX. INPUT TORQUE (IN.LB) | RATIO    | MECHANICAL ADVANTAGE | OUTPUT ANGULAR STROKE | TURN PER 90° | MAX. ROUND BORE (IN)         | MAX. SQUARE BORE (IN) | MAX. MOUNTING STRADDLE C/L (IN) | MIN. MOUNTING STRADDLE C/L (IN) | PREFERRED MOUNTING STRADDLE C/L (IN) |
|----------------------------|---------------------------|----------|----------------------|-----------------------|--------------|------------------------------|-----------------------|---------------------------------|---------------------------------|--------------------------------------|
| 942,000                    | 2599                      | 1450 : 1 | 362.5                | ± 20°                 | 36250        | 10.20"<br>Key: 2.75" x 1.60" | 7.25"                 | 24.50"                          | 15.50"                          | FA48                                 |



**DIAMOND GEAR CO. LTD.**

**HOUSTON, TEXAS, USA**

**PHONE: 713-590-0270, FAX: 713-590-0278**



C921123A

REV.0

05/22/09